

Real Time Drowsiness Detection System

**Mr. Shailesh Sangle, Bharat Rathore, Rishabh Rathod, Aakashkumar Yadav,
Abhishek Yadav**

*Assistant Professor Department Of Computer Engineering Thakur College Of Engineering & Technology
Department Of Computer Engineering Thakur College Of Engineering & Technology
Domain – Artificial Intelligence (Intelligent Systems)*

Abstract—The Proposed Paper Describes How Efficiently A Non-Intrusive Computer Vision Based Concept Be Used For Detecting Drowsiness Of The Driver. A System Will Be Developed Which Aims To Improve The Road Safety Using Advanced Technology. The Proposed System Will Use A Basic Web-Cam Interfaced With Raspberry-Pi That Points Directly Towards The Driver's Face And Monitors The Driver's Eyes And Face In Order To Detect Fatigue. If Symptoms Of Fatigue Such As Closed Eyes Or Head Lowering Occurs A Warning Signal Is Issued To Alert The Driver. The Product Prototype Proposed Is Unique To The Road Safety Purpose. It Uses The Concept Of Image Processing. Open-Cv Will Be Integrated With The Python And Deployed On Raspberry-Pi. Harr Classifier Algorithm Used Will Help To Determine If The Eyes Are Open Or Closed. The Algorithm Developed Is Unique To Any Currently Published Papers In Terms Of Its Application With Raspberry Pi, The Primary Objective Of The Project Was To Make The System Portable And Hence Can Be Applied In Existing Vehicles To Improve The Safety By Giving Driver A Feedback When He Feels Drowsy. The Algorithm Uses Image Binarization To Mark The Edges Of The Face. Once The Face Area Is Found, The Computation Of The Horizontal Averages In The Area Helps Us Locating The Eyes. Eye Regions In The Face Shows Great Intensity Changes, The Eyes Are Located By Facial Landmarks Detector File Which Is In Dlib Library. Once The Eyes Are Located, Distance Is Measured Between The Intensity Changes In The Eye Area Which Helps Us To Determine Whether The Eyes Are Open Or Closed. Large Distance Computed Corresponds To Eye Closure. If The Eyes Are Found Closed For Few Consecutive Frames, The System Draws The Conclusion That The Driver Is Falling Asleep And Issues A Warning Signal. There Is Also A Provision Of Monitoring The Head Region In The Frame, Similarly If For Few Consecutive Frames If The Head Region Is Out Of The Frame Also Triggers A Warning Condition. The System Is Also Able To Detect When The Eyes Cannot Be Found And Work Under Reasonable Lighting Conditions [5].

Keywords— Non-Intrusive, Face Detection, Eye Detection, Image Binarization, Harr Classifier And Drowsy Detection

I. Introduction

Driver Fatigue Is A Major Factor For A Large Number Of Road Vehicle Accidents. Recent Statistics Reports That 1,200 Deaths And 76,000 Injuries Are Reported Annually Due To Fatigue. The Technology Advancements For Detecting And Preventing Drowsiness Behind The Wheel Have Been A Major Challenge In The Domain Of Accident Prevention Systems. Because Of The Losses That Drowsiness Causes On The Roads, Methods Are Needed To Be Developed For Counteracting Its Effects [1]. The Objective Of The Project Is To Come Out With A Prototype Of Drowsiness Detection System. The Aim Will Be To Design A System That Will Monitor The Real-Time Status Of The Driver's Eyes Accurately. By Systemic Monitoring Of The Eyes And Head Position Symptoms Of Fatigue Will Be Detected Beforehand And Early Enough That Would Help Avoiding A Car Accident. For Detection Of Fatigue, Analysis Of Image Sequence Of A Face Is Done, And The Movement Of Eye And Blink Patterns Are Determined.

Face Images Analysis Is A Research Area With Many Applications Such As Face Recognition, Human Identification Security Systems And Virtual Tools [7]. In This Project We Will Mainly Focus On The Extraction Of The Eye Region, This Involves Considering The Entire Image Of The Face, And Then To Determine The Eye Region By Using A Self-Developed Image-Processing Algorithm And Once The Position Of The Eyes Are Located, The System Will Determine Whether The Eyes Are Opened Or Closed Along With The Position Of The Head And Accordingly Detect Fatigue.

While Developing A Driver Monitoring System, Two Issues Such As Driver Fatigue Measurement And Distraction Detection Should Be Solved. And Our Proposed System Solves Both By Monitoring The State Of Eyes We Can Trigger Warning If Driver Has Fallen Asleep. By Monitoring The Head Region In Particular Area Algorithm Can Monitor If Driver Is Alert Or Not.

II. Literature Review

Researchers Have Worked In Recent Times For Detection Of Driver Inattention, Mainly Focused On Drowsiness. There Have Been Lots Of Research On Sleep In The Field Of Psychology And Medicine And Accurate Indicators Of Sleep Have Been Developed [4]. Electrical Change In Brain Is Represented By Electroencephalograms (Eeg) [5] With The Help Of Electrode Placed On Scalp. Small Voltages Produced In The Brain Cortex Are Detected By These Electrodes. Waves Of Serval Frequencies Known As Alpha, Beta, And Gamma Are Formed Due To Potential Which Linked To Various Cognitive Processes, Drowsiness And Sleep Stages. With The Help Of Electrooculography (Eog), Brain Studies Couple Eeg, Which Helps To Detect Eye Movements, And Electromyogram (Emg) Monitors Muscular Tone. These Are Best Data For Drowsiness Detection And Many Drowsiness Detection Systems Make Use Of It. But They Require Electrode To Place On Drivers' Head Which Can Be Annoying Hence Problematic.

Eeg Requires External Help And Takes A Few Minutes, And Medical Equipment Is Always Expensive. Recent Research Has Introduced Some Contact-Less Readings, But No Remarkable Results Have Been Achieved So Far. Nonetheless, Physiological Measures Such As Eeg Have Been Used In Some Projects [6], And Are Frequently Used As The Ground Truth For Testing Other, Less Invasive Methods.

A Driver's State Of Attention Can Also Be Characterized Using Indirect Measurements And Contact-Less Sensors. Lateral Position Of The Vehicle Inside The Lane, Steering Wheel Movements And Time-To-Line Crossing Are Commonly Used,

And Some Commercial Systems Have Been Developed. These Systems Do Not Monitor The Driver's Condition, But Its Driving

Pattern And Gives A Result Which Is Not So Accurate. Hence, We Have Proposed This Technique To Monitor The Driver's Condition Over Driving Pattern. Thus In Our Proposed System We Will Prefer Haar Cascade Classifier As It Is Faster And Has Predefined Classes To Detect The Human Faces And Its Features Such As Eyes. This Will Thus Help Us To Determine The Blinks Of Eyes Easily.

III. Methodology

A Different Type Of Methodologies Has Been Developed To Find Out Driver Drowsiness So As To Prevent Road Accidents.

- (1) Physiological Level Approach-** This Technique Is An Intrusive Method Wherein Electrodes Are Used To Obtain Pulse Rate, Heart Rate And Brain Activity Information. Ecg Is Used To Calculate The Variations In Heart Rate And Also Detect Different Conditions For Drowsiness. The Correlation Between Different Signals Such As Ecg (Electrocardiogram), Eeg (Electroencephalogram), And Emg (Electromyogram) Are Made And Then The Output Is Generated Whether The Driver Is Drowsy Or Not.
- (2) Vehicle Based Approach-** This Technique Continuously Monitors The Position Of Car In Lane, Steering Wheel Position And Pressure On Acceleration Pedal. By Measuring All This Parameters System Indicates Whether Driver Is Drowsy Or Not.
- (3) Behavioral Based Approach-** In This Technique Eye Blinking Frequency, Head Pose, *Etc.*, Of A Driver Is Monitored Through A Camera And The Driver Is Alerted If Any Of These Drowsiness Symptoms Are Detected.

IV. Proposed System

Practically, Physiological Based Approach Is Not Suitable For Drowsiness Detection As It Is An Intrusive Method Which Is Not User Friendly For Driver And For Drowsiness Detection. Vehicle Based Approach Is Based On Monitoring The Car Instead Of Driver And Hence It Is Difficult To Determine Whether Driver Is Feeling Sleepy Or Not.

The Proposed System Consists Of Three Major Components:-

- 1. Capturing Frames:** Camera Mounted On The Dashboard Captures The Images Of Driver's Face Including Eyes And Passes This Data To Processing Component.
- 2. Processing And Detecting Component:** Captured Facial Image Is Used To Determine Whether Drivers' Eye Is Closed Or Open. The Driver's Current Eye State Is Determined By Using Harr Classifier Which Is Use For Object And Face Detection. For Detecting Eyes, We First Create A Facial Landmark Detector File Which Is Implemented Inside Dlib Library. Dlib Produces 68 (X,Y) Coordinates That Map To A Specific Facial Structure. Once We Plot These Points We Can Recognize Any Part Of The Face Such As Nose, Ear Etc. Below We Can Visualize That What Each Of These 68 Points Maps To:



Fig.1. Facial Landmark Indexes For Face Region [9]

Now, We Can See That Left Eye Coordinates Are From 37 To 42 And Right Eye Coordinates Are Form 43 To 48. Sample Pseudo Code For Detecting Facial Parts: Facial_Landmarks_Idxs = Ordereddict ([("Mouth", (49, 68)), ("Right_Eyebrow", (23, 27)), ("Left_Eyebrow", (18, 22)), ("Right_Eye", (43, 46)), ("Left_Eye", (37, 42)), ("Nose", (28, 36)), ("Jaw", (1, 17))])

- 3. Signaling:** After Processing The Eye Blink Frequency Decision Will Be Made Whether To Give Alarm To Driver Or Not. If Eyes Are Closed For More Than 22 Frames Then Alarm Will Be Given To Driver. For Signaling, A Buzzer Will Interfaced With Raspberry Pi.

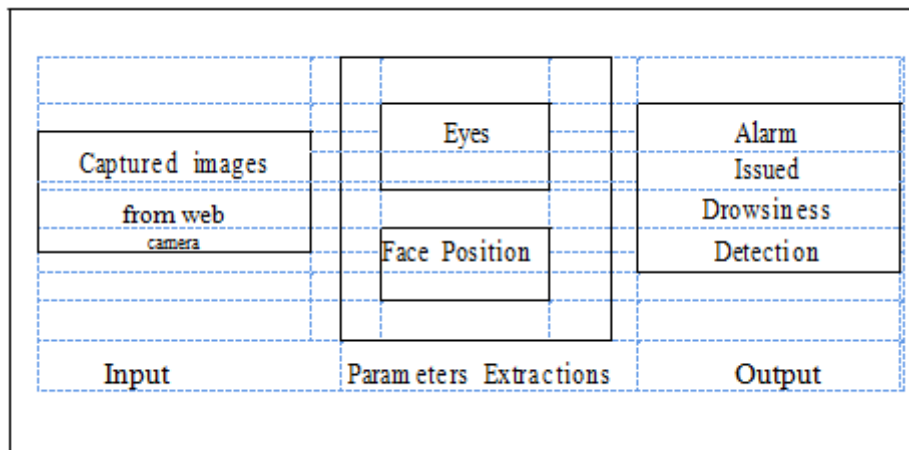

Fig.2. Block Diagram Of The Proposed System

A. Block Diagram

System Proposed By Us Will Have Open Source 3 Megapixel Digital Camera Which Will Capture Real Time Images Of Driver

.We Will Send These Captured Images To A Raspberry- Pi System Board. . The Raspberry-Pi System Is Loaded With Raspbian Os And Python Packages For Open Cv (Computer Vision). As Mentioned Above We Are More Focusing On Eye Part Of Driver Hence We Will Use Harr Features. For Edge Detection Of Pupil And Iris Hough Transform Is Used. We Have A Threshold Value For Pupils And Iris Area And Compare It With Current Value To Detect Drowsiness.

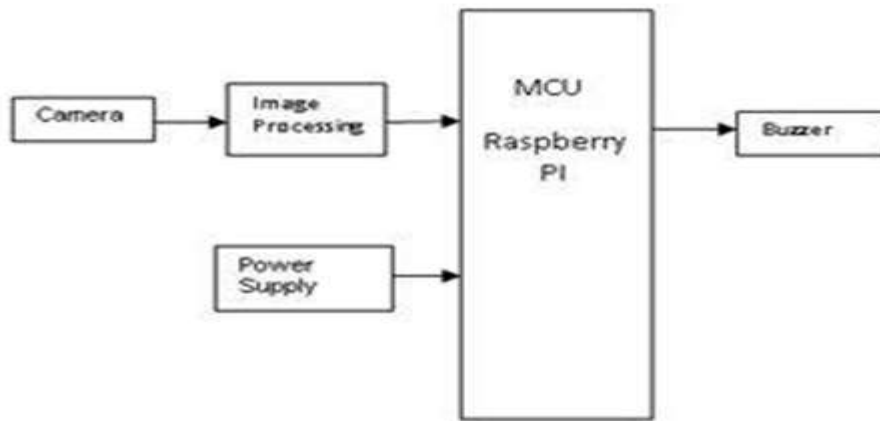

Figure 3. Block Diagram Of System

B. Flowchart

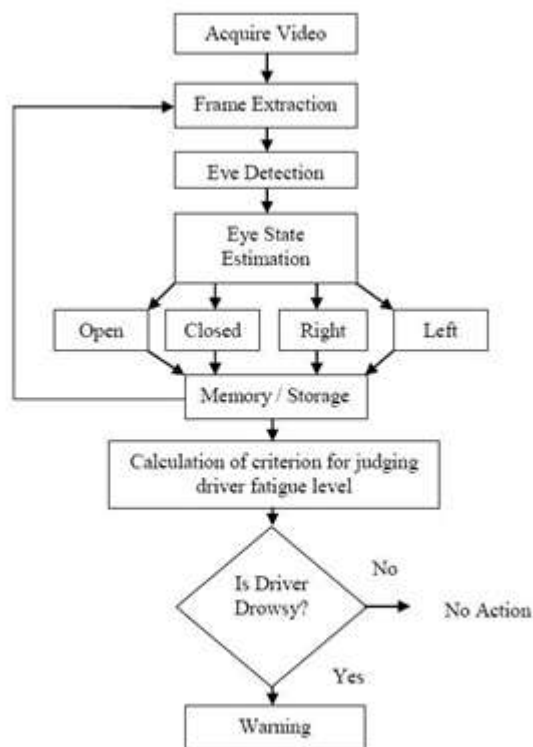

Figure 4.Flowchart [8]

V. System Requirements

A. Hardware Requirement

- I. Raspberry Pi 3b
- II. Buzzer
- III. Camera

B. Software Requirement

- I. Os: Linux
- Ii. Programming Language: Python, Open Cv
- Vi. Future Scope

We Are Currently Using Video Segment At 10 Fps And While Using Video Segment We Can Accurately Able To Detect Drowsiness But If We Try To Slow It Down Then It Is Not Working Accurately More

Short Of Hit And Miss. That's Why Our Future Scope Is To Increase The Frame Rate So That We Can Make Use Of The Entire Video Frame Segment. Each Person Has Different Eye Hence This System Can Be Developed As Much Reliable Eye State Database. Our Aim Is To Detect Drowsiness And In Future This System Will Be Integral Part Of Safety System In Vehicles And Used To Save Many Lives. In Future This Prototype Will Be Extended To Add Few More Features To Detect Driver Drowsiness. In Future This Prototype Will Be Extended To Add Few More Features To Detect Driver Drowsiness. In Future We Are Planning To Add Yawn Detection Method, Detection Of Sleep By Monitoring Head Movement. Further, This Prototype Will Be Extended To Monitor The Reflect Ray From Eye Using Nano Camera. If The Reflection Ray Is Absent, Then Eye Is Closed Otherwise Eye Is Opened. We Believe That This Will Create A Better Opportunity To Detect Drowsiness.

VI. Conclusion

We Use Eye Aspect Ratio To Identify Drowsiness. It Acts As An Indicator For Drowsiness. Video Captured By Camera Is Use To Extract Frames And These Frames Are Used As Input To Extract Eye Region With The Help Of Eye Region Extractor. Eye Region Extractor Help Us To Find Eye Region Which Are Gray Scaled, Resized And Histogram Equalized. After This Step, If An Eye Remains Closed For Constantly 15 Frames. For Generating Alert Message To Driver Average Value Of Eye State Must Be Constantly Near To The Zero Value. In Our Paper We Have Reviewed All The Methods Available To Detect Drowsiness. Physiological, Vehicle Based And Behavioral Measures Are Various Method Used For Detection Of Driver Drowsiness. Out Of All These Methods When We Use Physiological Method Accuracy Rate Is High For Detection Of Drowsiness, But Physiological Method Is Highly Intrusive Which Makes It Difficult To Use.

In Our Prototype, We Are Using A Non-Intrusive Method To Detect Drowsiness Of Driver By Monitoring Driver Eye Movement. If Eye Remain Close For More Than Certain Time Then Alarm Is Generated And Also Continues Monitoring Make This System More Accurate.

VII. Results



Figures 5. Eyes Are Open

The Eyes Are Marked With Ellipse Shaped Markers Which Help Us To Determine The Eye Region. Monitoring The Ear (Eye Aspect Ratio) Will Determine The Eyes Are Opened Or Closed. An Open Eye Will Have Ear Value Greater Than 0.2 In All Conditions.



Figures 6. Eyes Are Closed (Drowsiness Alert)

The Above Result Shows Us The Ellipse Shaped Marker Has Turned Out To Become A Flat Line And Ear Has Dropped Below 0.2 This Will Generate Alarm. If Ear Stays Less Than 0.2 For 15 Consecutive Frames. We Have Achieved 92% Accuracy By Testing The Prototype Using Different Video Input Streams. Our Prototype Is Highly Capable Of Determining Status Of Eyes, Even If The Driver Wears Spectacles As Seen In The Above Fig.

References

- [1]. U.S. Dept. Of Transportation, "Traffic Safety Facts 2006: A Compilation Of Motor Vehicle Crash Data
- [2]. From The Fatality Analysis Reporting System And The General Estimates System," Tech. Report Dot-Hs 810 818, Nat'l Highway Traffic Safety Administration, 2006.
- [3]. [Http://www.lboro.ac.uk/departments/ssehs/research/be-ha-via-rural-medicine/sleep-research-centre/](http://www.lboro.ac.uk/departments/ssehs/research/be-ha-via-rural-medicine/sleep-research-centre/)
- [4]. Y. Liang, "Detecting Driver Distraction," Ph. D Thesis, University Of Iowa, 2009.
- [5]. M. Baly, B. Fildes, M. Regan, And K. Young, "Review Of Crash Effectiveness Of Intelligent Transport System," Traffic Accident Causation In Europe (Trace), 2007.
- [6]. E. Rogado, J. Garcia, R. Barea, L. Bergasa And E. Lopez, "Driver Fatigue Detection System," Proc. Ieee Int. Conf. Robotics And Biomimetics, 2009.
- [7]. S. Abtahi, "Driver Drowsiness Monitoring Based On Yawning Detection," Ms Thesis, University Of Ottawa, 2012.
- [8]. Jayasenan J.S. "Driver Drowsiness Detection System" Iosr Journal Of Vlsi And Signal Processing Vol. 4 –
- [9]. Jan 2014.
- [10]. [Http://sine.ni.com/cs/app/doc/p/id/cs-13515-9](http://sine.ni.com/cs/app/doc/p/id/cs-13515-9)<https://ibug.doc.ic.ac.uk/resources/facial-point-annotation>